



#### Product Summary

$V_{(BR)DSS}$	$R_{DS(on)TYP}$	$I_D$
40V	17mΩ@10V	18A
	23mΩ@4.5V	
-40V	42mΩ@-10V	-17A
	68mΩ@-4.5V	

#### Feature

- Trench Technology Power MOSFET
- Low  $R_{DS(ON)}$
- Low Gate Charge
- Low Gate Resistance

#### Application

- PWM Applications
- Load Switch
- Power Management

#### MARKING:

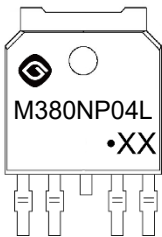

M380NP04L = Device Code  
 XX = Data Code  
 Solid Dot = Green Device Indicator

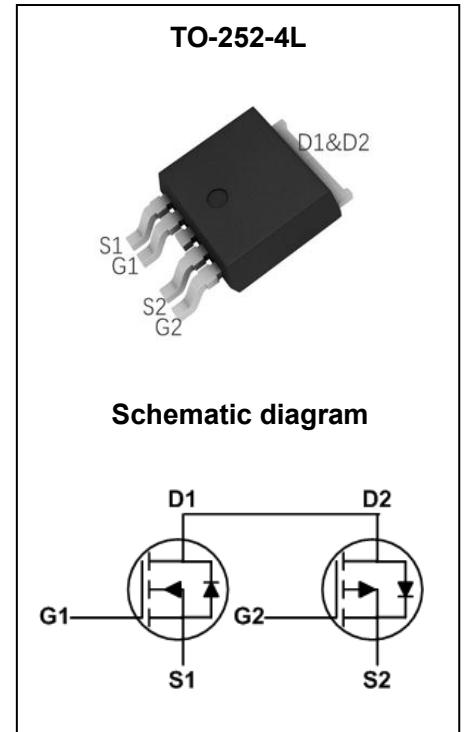

#### ABSOLUTE MAXIMUM RATINGS ( $T_A = 25^\circ\text{C}$ unless otherwise noted)

Parameter	Symbol	NMOS	PMOS	Unit
Drain - Source Voltage	$V_{DS}$	40	-40	V
Gate - Source Voltage	$V_{GS}$	$\pm 20$	$\pm 20$	V
Continuous Drain Current <sup>1</sup>	$I_D$	18	-17	A
$T_C = 25^\circ\text{C}$				
Pulsed Drain Current <sup>2</sup>	$I_{DM}$	72	-68	A
Single Pulsed Avalanche Current <sup>3,4</sup>	$I_{AS}$	10	12	A
Single Pulsed Avalanche Energy <sup>3,4</sup>	$E_{AS}$	25	36	mJ
Power Dissipation <sup>6</sup>	$P_D$	41.5	41.5	W
Thermal Resistance from Junction to Ambient <sup>7</sup>	$R_{\theta JA}$	60	60	$^\circ\text{C}/\text{W}$
Thermal Resistance from Junction to Case	$R_{\theta JC}$	5.5	5	$^\circ\text{C}/\text{W}$
Junction Temperature	$T_J$	150	150	$^\circ\text{C}$
Storage Temperature	$T_{STG}$	-55~ +150	-55~ +150	$^\circ\text{C}$

## MOSFET ELECTRICAL CHARACTERISTICS ( $T_A = 25^\circ\text{C}$ unless otherwise noted)

### NMOS:

Parameter	Symbol	Test Condition	Min	Type	Max	Unit
<b>Off Characteristics</b>						
Drain - Source Breakdown Voltage	$V_{(BR)DSS}$	$V_{GS} = 0V, I_D = 250\mu A$	40			V
Zero Gate Voltage Drain Current	$I_{DSS}$	$V_{DS} = 40V, V_{GS} = 0V$			1	$\mu A$
Gate - Body Leakage Current	$I_{GSS}$	$V_{GS} = \pm 20V, V_{DS} = 0V$			$\pm 100$	nA
<b>On Characteristics<sup>3</sup></b>						
Gate Threshold Voltage	$V_{GS(th)}$	$V_{DS} = V_{GS}, I_D = 250\mu A$	1.0	1.7	3.0	V
Drain-source On-resistance	$R_{DS(on)}$	$V_{GS} = 10V, I_D = 6A$		17	26	m $\Omega$
		$V_{GS} = 4.5V, I_D = 6A$		23	39	
<b>Dynamic Characteristics</b>						
Input Capacitance	$C_{iss}$	$V_{DS} = 20V, V_{GS} = 0V, f = 1MHz$		702		pF
Output Capacitance	$C_{oss}$			59		
Reverse Transfer Capacitance	$C_{rss}$			48		
Gate Resistance	$R_g$	$V_{DS} = 0V, V_{GS} = 0V, f = 1MHz$		3.6		$\Omega$
<b>Switching Characteristics</b>						
Total Gate Charge	$Q_g$	$V_{DS} = 20V, V_{GS} = 10V, I_D = 6A$		20		nC
Gate-source Charge	$Q_{gs}$			2.8		
Gate-drain Charge	$Q_{gd}$			6		
Turn-on Delay Time	$t_{d(on)}$	$V_{DD} = 20V, V_{GS} = 10V, R_G = 2.5\Omega, R_G = 3\Omega$		5		ns
Turn-on Rise Time	$t_r$			3		
Turn-off Delay Time	$t_{d(off)}$			15		
Turn-off Fall Time	$t_f$			2		
<b>Source - Drain Diode Characteristics</b>						
Diode Forward Voltage <sup>3</sup>	$V_{SD}$	$V_{GS} = 0V, I_S = 1A$			1.2	V

## PMOS:

Parameter	Symbol	Test Condition	Min	Type	Max	Unit
<b>Off Characteristics</b>						
Drain - Source Breakdown Voltage	$V_{(BR)DSS}$	$V_{GS} = 0V, I_D = -250\mu A$	-40			V
Zero Gate Voltage Drain Current	$I_{DSS}$	$V_{DS} = -40V, V_{GS} = 0V$			-1	$\mu A$
Gate - Body Leakage Current	$I_{GSS}$	$V_{GS} = \pm 20V, V_{DS} = 0V$			$\pm 100$	nA
<b>On Characteristics<sup>3</sup></b>						
Gate Threshold Voltage	$V_{GS(th)}$	$V_{DS} = V_{GS}, I_D = -250\mu A$	-1.0	-2.1	-3.0	V
Drain-source On-resistance	$R_{DS(on)}$	$V_{GS} = -10V, I_D = -5A$		42	55	m $\Omega$
		$V_{GS} = -4.5V, I_D = -5A$		68	86	
<b>Dynamic Characteristics</b>						
Input Capacitance	$C_{iss}$	$V_{DS} = -20V, V_{GS} = 0V, f = 1MHz$		671		pF
Output Capacitance	$C_{oss}$			67		
Reverse Transfer Capacitance	$C_{rss}$			51		
Gate Resistance	$R_g$	$V_{DS} = 0V, V_{GS} = 0V, f = 1MHz$		24		$\Omega$
<b>Switching Characteristics</b>						
Total Gate Charge	$Q_g$	$V_{DS} = -20V, V_{GS} = -10V, I_D = -5A$		18.4		pC
Gate-source Charge	$Q_{gs}$			3.1		
Gate-drain Charge	$Q_{gd}$			5.6		
Turn-on Delay Time	$t_{d(on)}$	$V_{DD} = -20V, V_{GS} = -10V,$ $R_G = 2.3\Omega, R_G = 6\Omega$		8		ns
Turn-on Rise Time	$t_r$			6		
Turn-off Delay Time	$t_{d(off)}$			20		
Turn-off Fall Time	$t_f$			7		
<b>Source - Drain Diode Characteristics</b>						
Diode Forward Voltage <sup>3</sup>	$V_{SD}$	$V_{GS} = 0V, I_S = -1A$			-1.2	V

### Notes :

- 1.The maximum current rating is limited by package.And device mounted on a large heatsink
- 2.Pulse Test : Pulse Width  $\leq 10\mu s$ , duty cycle  $\leq 1\%$ .
- 3.EAS condition:  $V_{DD} = 20V, V_{GS} = 10V, L = 0.5mH, R_G = 25\Omega$  Starting  $T_J = 25^\circ C$ .
- 4.EAS condition:  $V_{DD} = -20V, V_{GS} = -10V, L = 0.5mH, R_G = 25\Omega$  Starting  $T_J = 25^\circ C$ .
- 5.Pulse Test : Pulse Width  $\leq 300\mu s$ , duty cycle  $\leq 2\%$ .
- 6.The power dissipation  $P_D$  is limited by  $T_{J(MAX)} = 150^\circ C$ .And device mounted on a large heatsink
- 7.Device mounted on  $1in^2$  FR-4 board with 2oz. Copper, in a still air environment with  $T_A = 25^\circ C$ .

## TO-252-4L Package Information

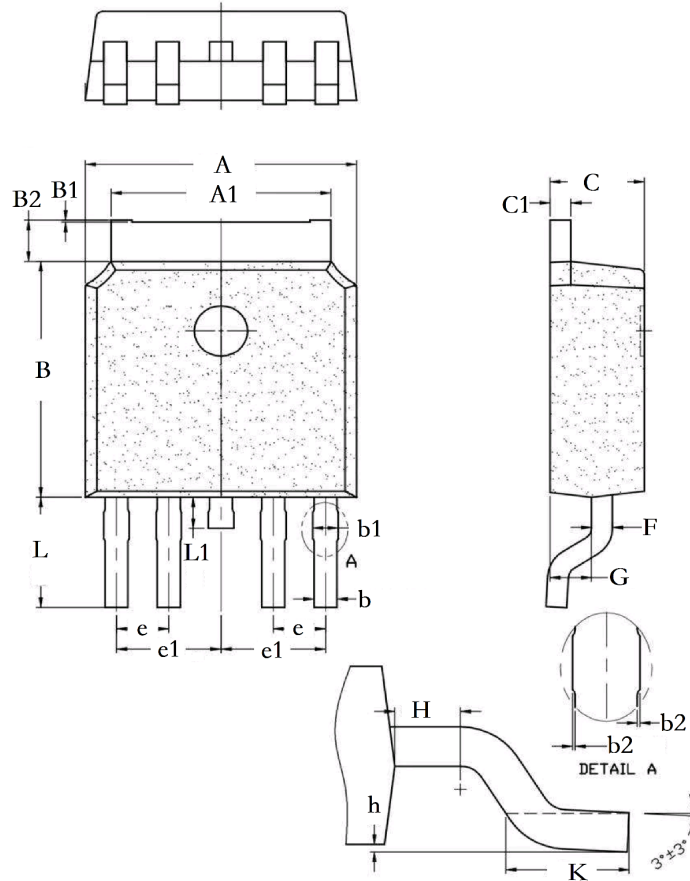

Symbol	Dimensions In Millimeters		Dimensions In Inches	
	Min.	Max.	Min.	Max.
A	6.550	6.650	0.258	0.262
A1	5.234	5.434	0.206	0.214
B	6.050	6.150	0.238	0.242
B1	0.000	0.050	0.000	0.002
B2	0.962	1.162	0.038	0.046
C	2.250	2.350	0.089	0.093
C1	0.458	0.558	0.018	0.022
L	2.698	2.998	0.106	0.118
L1	0.700	0.900	0.028	0.035
b	0.510	0.610	0.020	0.024
b1	0.570	0.670	0.022	0.026
b2	0.000	0.050	0.000	0.002
e	1.270TYP		0.050TYP	
e1	2.540TYP		0.100TYP	
F	0.458	0.558	0.018	0.022
G	0.960	1.06	0.038	0.042
H	0.650	0.950	0.026	0.037
h	0.050	0.150	0.002	0.006
K	1.300	1.700	0.051	0.067